

# ZS1210, 8-Port USB Relay

*User Manual*

---

2.0, Apr 2025





## Table of Contents

1. Revision History .....	1
2. Introduction .....	2
2.1. Operation .....	2
2.2. Specification .....	2
2.3. Applications .....	3
2.4. Ordering Information .....	3
3. Device Usage .....	4
3.1. Connection Details .....	4
3.2. Serial Port Setting .....	4
3.3. Command Line Interface .....	5
3.4. Sample Python Code .....	6
A. Limited Hardware Warranty .....	7
A.1. LIMITED HARDWARE WARRANTY .....	7
A.2. EXCLUSIONS .....	7
A.3. HARDWARE RETURN PROCEDURES .....	7
A.4. HARDWARE REPLACEMENT PROCEDURES .....	8
A.5. ADDITIONAL RESPONSIBILITIES .....	8
A.6. LIMITATION OF LIABILITY .....	8

# Chapter 1. Revision History

Revision	Date	Comment
1.0	02 Apr, 2024	Initial Revision.
1.1	03 Feb, 2025	Product Code Updated.
2.0	25 Apr, 2025	Remove product and model name commands.

# Chapter 2. Introduction

USB Relay is a host-controllable, 8 port relay device. It is capable of switching on/off one or more of the 8 relay ports according to the serial command provided.

## 2.1. Operation

USB Relay is detected as a USB serial device when connected to a PC. It has built-in command engine that accepts commands via the USB serial interface. Based on the input command, the USB Relay switches on/off any one or more of the 8 relay ports.

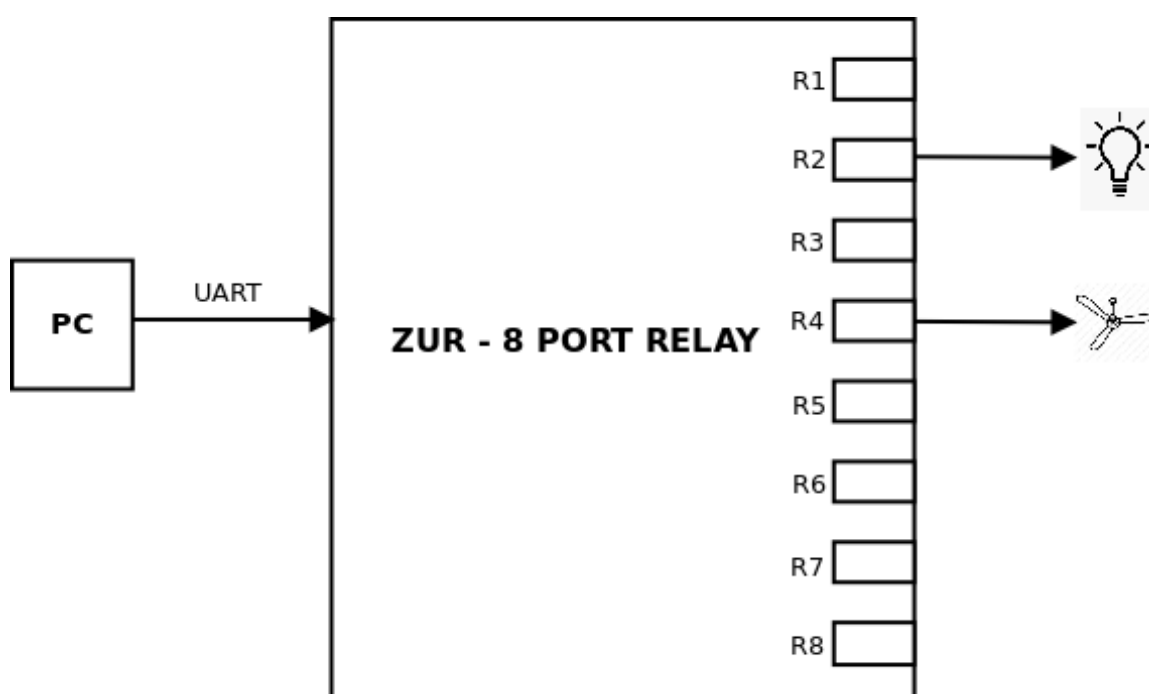

## 2.2. Specification

Parameter	Value
Relay Ports	8
Power Supply	12V,1A
Maximum Switching Voltage	250VAC/30VDC
Maximum Switching Current	15A
Contact Rating (NO)	7A 250VAC, 12A 120VDC
Contact Rating (NC)	10A 120VAC, 10A 24VDC
Life Expectancy (Electrical)	1,00,000
Life Expectancy (Mechanical)	10,00,000
Contact Resistance	50mΩ Max at 6VDC 1A
Maximum Switching On Response Time	10msec
Maximum Switching Off Response Time	5msec
Control Port	USB Mini-B

## 2.3. Applications

- Test Automation
  - Power control
  - Reset control
  - Digital output control
- Industrial Automation
- Home Automation

## 2.4. Ordering Information

- Product Name: ZS1210, 8-Port USB Relay
- Model No : ZS-USBRLY8-P1A

# Chapter 3. Device Usage

USB Relay is detected as a USB serial device in the PC and it helps the PC to communicate and control this module seamlessly. The Connection details, Serial port settings and the list of available commands are discussed in the upcoming sections.

## 3.1. Connection Details

### 3.1.1. Relay Interface

There are three contacts in each USB Relay.

- C - Common terminal
- NO - Normally Open
- NC - Normally Closed

Behaviour of the contacts:

- When the relay is turned off, the contacts NC and C will be connected.
- When the relay is turned on, the contacts NO and C will be connected.

### 3.1.2. USB Interface

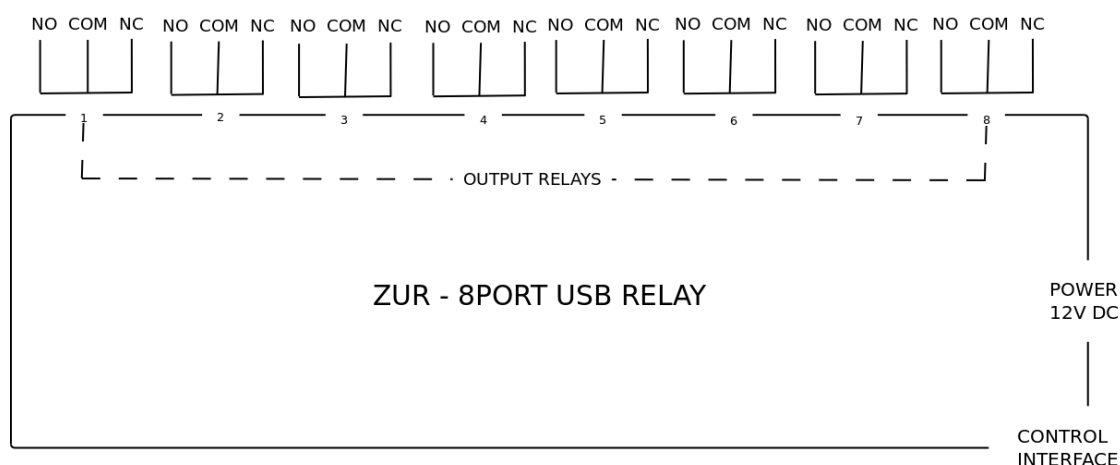

- Power up USB Relay using the given (12V) power adapter
- Plug the USB mini Type B cable from USB Relay to the control interface (ie., PC) and it will get detected as a USB Serial Device.
- In Windows OS, the device can be found as COM port under [Ports (COM and LPT)] section of device manager. If the device is not detected properly, the driver can be downloaded from the site <http://www.ftdichip.com/Drivers/VCP.htm>

## 3.2. Serial Port Setting

In order to establish serial communication between the USB Relay and the control PC, the following parameters has to be set accordingly.

Parameter	Value
Baud Rate	115200

---

Parameter	Value
No. Bits	8
Stop bit	1
Parity	No
Flow Control	No

---

### 3.3. Command Line Interface

The USB Relay is designed to accept requests through serial commands from the control PC.

- Each command should end with **CR LF** (`\r\n`).
- Device will respond back with the **OK** on success, **ER: <msg>** on failure.
- Commands are case-insensitive.
- The available commands are listed below.

#### 3.3.1. Version

The **V** command can be used to retrieve the firmware version of the device. An example command and response is shown below.

```
V\r\n1.2.0\nOK
```

#### 3.3.2. Power Command

The **Ps** command can be used to check whether the USB Relay is powered on or off (ie., whether it is connected to the 12V Adapter or not). An example command and response is shown below.

```
Ps\r\nON/OFF\nOK
```

#### 3.3.3. Write Command

The **W<hex>** command can be used to control multiple ports simultaneously. The ports to be turned ON / OFF should be provided as single byte argument, in hexadecimal format. Bit N in the byte corresponds to port (N+1). If the bit is 0, the corresponding port will be turned OFF, if the bit is 1, the corresponding port will be turned ON.

```
W55\r\nOK
```

#### 3.3.4. Read command

The **R** command can be used to read the status of the ports in the USB Relay. The status of all the ports is returned as a single byte in hexadecimal format. Bit N in the byte corresponds to port (N+1). If the bit is 0, the corresponding port is OFF, if the bit is 1, the corresponding port is ON. An example command and response is shown below.

```
R\r\n55
```

```
OK
```

### 3.3.5. Set command

The `S<port_no>` command can be used to turn on a single port that is specified in the command. The `<port_no>` should be in the range of 1 to 8 to turn on the relay ports 1 to 8 respectively. To turn on all ports, `Sa` command can be given. An example command and response is shown below.

```
S1\r\n
OK
```

### 3.3.6. Clear Command

The `C<port_no>` command can be used to turn off a single port that is specified in the command. The `<port_no>` should be in the range of 1 to 8 to turn on the relay ports 1 to 8 respectively. To turn off all ports, `Ca` command can be given. An example command and response is shown below.

```
C1\r\n
OK
```

## 3.4. Sample Python Code

The serial commands specified above can be given through Python, using the `pyserial` package. Follow the instructions in <https://github.com/pyserial/pyserial> to install the `pyserial`.

The `serial` module can be imported, as shown below.

```
import serial
```

Serial communication can then be established with the specified serial port settings.

```
ser = serial.Serial('/dev/ttyUSB0', 115200)
```

Now, that the serial communication is established, the serial commands can be given to the USB Relay.

For instance, to turn on port 1, the command can be given as shown below.

```
ser.write(b'S1')
ser.write(b'\r\n')
```

Similarly, to turn off port 1, the command can be given as shown below.

```
ser.write(b'C1')
ser.write(b'\r\n')
```

# Appendix A. Limited Hardware Warranty

The warranties provided by Zilogic Systems in this Limited Hardware Warranty apply only to Hardware Products you purchase for your use, and not for resale. The term "Hardware Product" means a computing device with a specific function and limited configuration ability.

## A.1. LIMITED HARDWARE WARRANTY

Zilogic Systems warrants that the hardware components of its Hardware Product shall be free from material defects in design, materials, and workmanship and will function, under normal use and circumstances, in accordance with the documentation provided, for a period of one (1) year from the date of purchase of the Hardware Product.

Your sole and exclusive remedy, and Zilogic Systems' sole and exclusive liability for defective hardware components, shall be that Zilogic Systems, subject to the terms and conditions of this Section, and solely upon confirmation of a defect or failure of a hardware component to perform as warranted, shall at its sole option, either repair or replace the nonconforming hardware component. All replacement parts furnished to you under this warranty shall be refurbished and equivalent to new, and shall be warranted as new for the remainder of the original warranty period. All defective parts, which have been replaced, shall become the property of Zilogic Systems. All defective parts that have been repaired shall remain your property.

## A.2. EXCLUSIONS

The foregoing warranties and remedies shall be void as to any Hardware Products damaged or rendered unserviceable by one or more of the following: (1) improper or inadequate maintenance by anyone other than Zilogic Systems or Zilogic Systems' authorized engineers, (2) interfacing supplied by anyone other than Zilogic Systems, (3) modifications, alterations or additions to the Hardware Products by personnel not certified by Zilogic Systems or Zilogic Systems' authorized engineers to perform such acts, or other unauthorized repair, installation or other causes beyond Zilogic Systems' control, (4) unreasonable refusal to agree with engineering change notice programs, (5) negligence by any person other than Zilogic Systems or Zilogic Systems' authorized engineers, (6) misuse, abuse, accident, electrical irregularity, theft, vandalism, fire, water or other peril, (7) damage caused by containment and/or operation outside the environmental specifications for the Hardware Products, (8) alteration or connection of the Hardware Products to other systems, equipment or devices (other than those specifically approved by Zilogic Systems) not in accordance to the board and on-board device specifications (9) any use that is inconsistent with the user manual supplied with the Hardware Product. The warranty period is not extended if Zilogic Systems repairs or replaces a warranted product or any parts. Zilogic Systems may change the availability of limited hardware warranties, at its discretion, but any changes will not be retroactive.

## A.3. HARDWARE RETURN PROCEDURES

If a Hardware Product or one of its component parts does not function as warranted during the warranty period, and such nonconformance can be verified by Zilogic Systems, Zilogic Systems, at its election, will provide either return and replacement service or replacement with a refurbished part/unit for the Hardware Product under the type of warranty service Zilogic Systems designates for that Hardware Product. A defective Hardware Product or one of its component parts may only be returned to Zilogic Systems upon Zilogic Systems' prior written approval. Any such approval shall reference an RMA number issued by an authorized Zilogic Systems service representative. If

you do not register the Hardware Product with Zilogic Systems, you may be required to present proof of purchase as evidence of your entitlement to warranty service. The Hardware Product's serial number will be required for all RMA cases.

Transportation costs, if any, incurred in connection with the return of a defective item to Zilogic Systems shall be borne by You. Any transportation costs incurred in connection with the redelivery of a repaired or replacement item to You by Zilogic Systems shall be borne by Zilogic Systems; provided, however, that if Zilogic Systems determines, in its sole discretion, that the allegedly defective item is not covered by the terms and conditions of the warranty or that a warranty claim is made after the warranty period, the cost of the repair by Zilogic Systems, including all shipping expenses, shall be reimbursed by You.

## **A.4. HARDWARE REPLACEMENT PROCEDURES**

Zilogic Systems will attempt to diagnose and resolve your problem over the phone or e-mail. Upon determination of the hardware issue is related to a malfunction of one of the Hardware Product components, an RMA process will be initiated by Zilogic Systems.

For Warranty Replacement service, it is required that you deliver the faulty unit to a location Zilogic Systems designates, and provide courier name and tracking number to Zilogic Systems. After the Faulty unit is returned to Zilogic Systems, Zilogic Systems will use commercially reasonable efforts to ship the replacement hardware within fourteen (14) business days. Actual delivery times may vary depending on availability of the spares and customer's location.

## **A.5. ADDITIONAL RESPONSIBILITIES**

You agree:

- To provide Zilogic Systems or its partner with sufficient and safe access to your facilities to permit Zilogic Systems to fulfill its obligations.
- To ship back the faulty Hardware Product (or replaceable unit) suitably packaged, quoting the RMA number, to the Zilogic Systems designated location.
- You shall ship the faulty Hardware Product once Zilogic Systems approves the RMA and provide the courier name and tracking number.
- To securely erase from any Hardware Product you return to Zilogic Systems for any reason all programs and data not provided by Zilogic Systems with the Hardware Product. You acknowledge that in order to perform its responsibilities under this Limited Hardware Warranty, Zilogic Systems may ship all or part of the Hardware Product or its software to third party locations around the world, and you authorize Zilogic Systems to do so.

## **A.6. LIMITATION OF LIABILITY**

Zilogic Systems' development kits are not designed, authorized or warranted to be suitable for use in medical, military, aircraft, space or life support equipment, not in applications where failure or malfunction of a Zilogic Systems product can reasonably be expected to result in personal injury, death or severe property or environmental damage.

NOTWITHSTANDING ANYTHING ELSE IN THIS AGREEMENT OR OTHERWISE, NEITHER ZILOGIC SYSTEMS NOR ITS SUPPLIERS WILL BE LIABLE WITH RESPECT TO ANY SUBJECT MATTER OF THIS AGREEMENT UNDER ANY CONTRACT, NEGLIGENCE, STRICT LIABILITY, OR OTHER LEGAL OR EQUITABLE THEORY, REGARDLESS OF WHETHER ZILOGIC SYSTEMS OR ITS SUPPLIERS WERE ADVISED OF THE POSSIBILITY OF SUCH DAMAGES, FOR: (i) ANY PUNITIVE, INCIDENTAL OR CONSEQUENTIAL DAMAGES OR LOST DATA OR LOST PROFITS; OR (ii) FOR COSTS OF PROCUREMENT OF SUBSTITUTE GOODS, TECHNOLOGY OR SERVICES; OR (iii) FOR ANY CLAIMS BASED ON ANY ERROR,

DEFECT OR NONCONFORMITY IN THE PRODUCTS OR SERVICE, FOR ANY AMOUNT IN EXCESS OF THE PRICE PAID TO ZILOGIC SYSTEMS FOR SUCH DEFECTIVE PRODUCT(S) OR SERVICE; OR (IV) FOR ALL OTHER CLAIMS NOT RELATED TO AN ERROR, DEFECT OR NONCONFORMITY IN THE PRODUCTS, ANY AMOUNTS IN EXCESS IN THE AGGREGATE OF THE AMOUNT PAID TO ZILOGIC SYSTEMS HEREUNDER DURING THE THREE (3) MONTHS PRECEDING THE DATE THE CAUSE OF ACTION AROSE.

WARRANTY DISCLAIMER. EXCEPT AS STATED HEREIN, ZILOGIC SYSTEMS MAKES NO WARRANTIES WITH RESPECT TO any PRODUCT, license or SERVICE AND DISCLAIMS ALL Statutory or IMPLIED WARRANTIES, INCLUDING WITHOUT LIMITATION WARRANTIES OF MERCHANTABILITY, FITNESS FOR A PARTICULAR PURPOSE, or arising from a course of dealing or usage of trade and any WARRANTIES OF NONINFRINGEMENT. ZILOGIC SYSTEMS DOES NOT WARRANT THAT THE ZILOGIC SYSTEMS PRODUCT(S) WILL MEET any REQUIREMENTS or THAT THE OPERATION OF ZILOGIC SYSTEMS PRODUCTS WILL BE UNINTERRUPTED OR ERROR FREE.